

HRI-R22t series

INSULATION MONITORING
VERSIONS FOR USE IN MEDICAL ROOMS

GENERAL

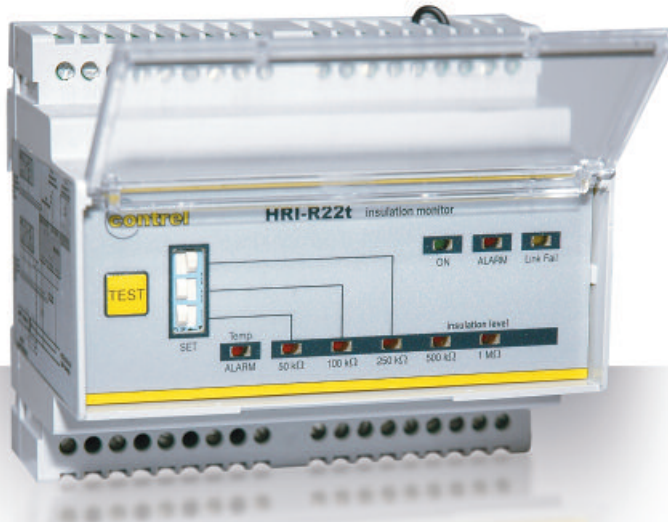

HRI-R22t series

The device has similar characteristics of previous model but it's more cheap and it has less functions.

There is measuring signalling and it is able to verify temperature of insulation' power transformer (1 PTC input with contact NO or NC directly supplied by device) and insulation's level.

These inputs are available: for remote repeaters panels PR2 and PR2-t and 1 relay NO-C-NC, that is activate when fixed threshold (insulation and temperature) are over-ride. HRI-R22t has frontally a bar led for visualising insulation's level of device and eventual alarm's presence is visualised frontally by led.

Testing button is available and it works for monitoring insulation's level preset with calibration on relay (for example, with 50 kohm calibration all the led with inferior limit of 50 kohm will light during the test).

This button monitors eventual remote reply panels PR2 and PR2-t (max 4 panels).

FUNCTIONS AND OPERATORS - LEGENDA

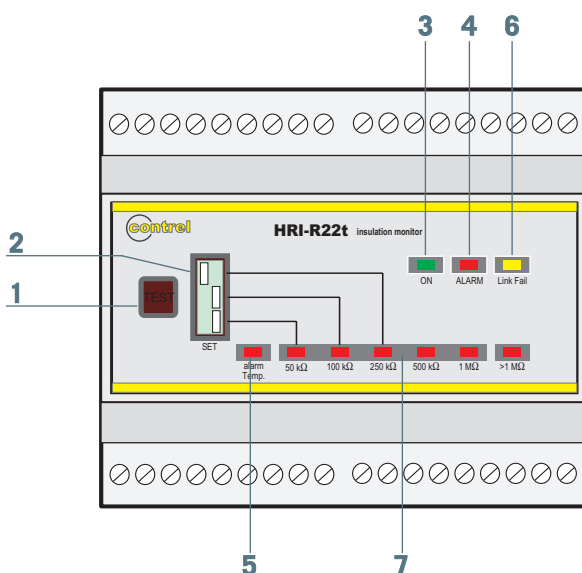

1 TEST PUSHBUTTON

2 MICRO SWITCH for threshold set

- turning the switch to right, corresponding insulation's resistance degree has to be digit, highest degree heads
- with all the switches turned to left, fixed degree of 50 kohm doesn't change

3 LED signalling supplied relay

4 LED signalling pre-fixed insulation's threshold reached

5 LED signalling temperature's threshold reached

6 LED signalling relay connected correctly

7 LED signalling instant insulation's value of device, identified by lowest degree between active led

ELECTRIC CHARACTERISTICS

TIPO	HRI-R22t
Auxiliary supply	230 V \pm 20%
Frequency	50 \div 60 Hz
Self-consumption	3 VA
Unde-control network voltage	24 \div 230 V 50 \div 60 Hz
Voltage's measure	< 15 V
Current's measure	< 0.6 mA
Internal impedance for resistive measure	1 Mohm
Selectable trip threshold	50-100-250 kohm (low insulation) by switches
Visualisation	led of insulation value by led bar 50 \div 1000 kohm led of signalling network's presence led of signalling low insulation led of signalling over-temperature led of failed insertion signalling
Output	for panel PR2 and PR2-t (max 4) total + 1 contact NO-C-NC 5 A - 250 V (low insulation) + 1 contact NO-C-NC 5 A - 250 V (over-temperature)
Input	from isolated network 230 Vac (insulation measure) PTC probe (temperature measurement)
Voltage of signal circuit	< 24 Vdc
Measure's method	signalling dc
Insulation's test	2.5 kV 60 sec
Working temperature	-10 \div 60 °C
Storing temperature	-20 \div 80 °C
Relative humidity	MAX 90 %
Standard regulation	CEI-EN 61010-1 / CEI-EN 61557-8 / VDE 0413 part.8 CEI 64.8/7-710 V2 / IEC 60364-7-710 / UNE 20615 / CEI-EN 61326-1
Assembling according to DIN 50022	snap on DIN rail 35 mm
Dimensions	6 modules DIN 17.5 mm
Protection's degree	IP50 frontal - IP20 case
Connections	by screw terminals max 2.5 mm ²

WIRING DIAGRAMS - LEGENDA

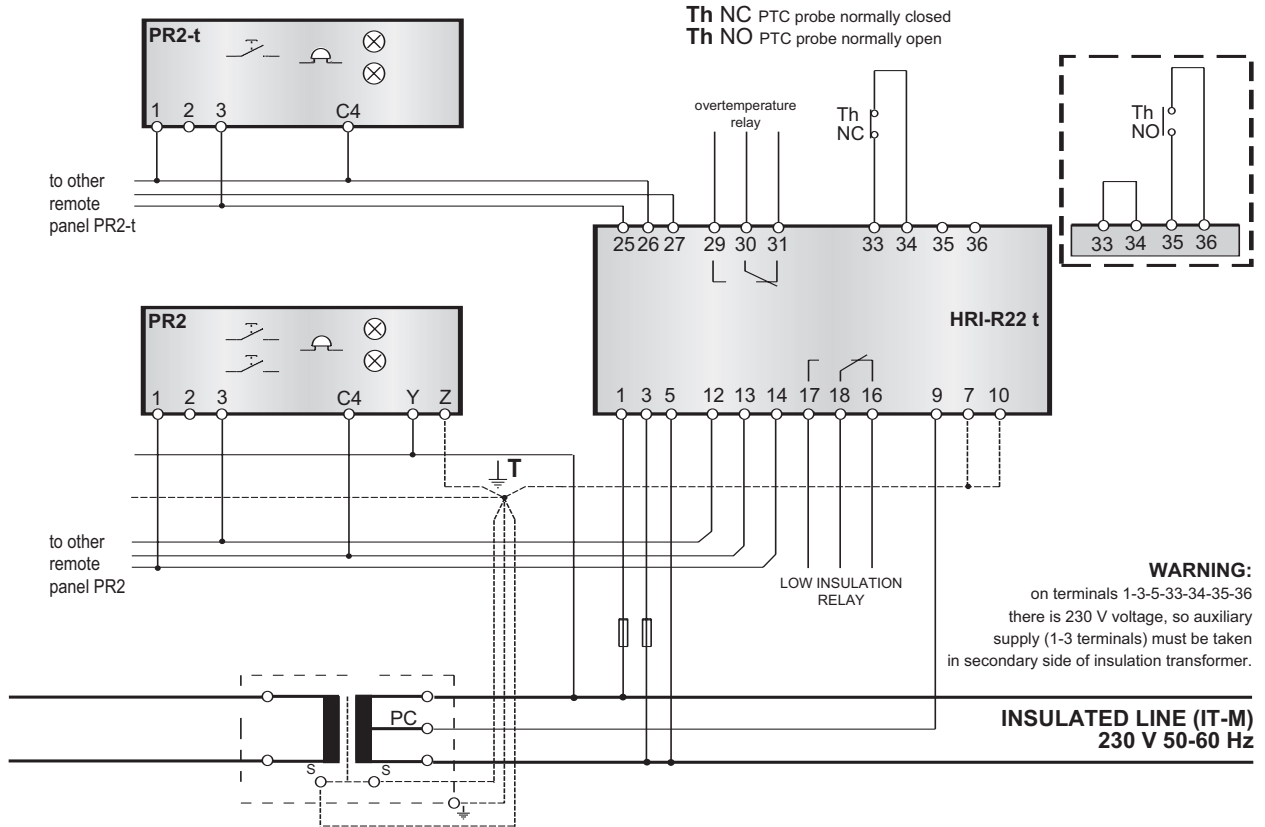

AUXILIARY SUPPLY - TERMINALS 1-3

MONITORING INSULATION - TERMINALS 5-9

both terminals have to be connected between centre tap of secondary transformer or isolated network's phase and unipotential node (PE). Maximum voltage applicable is 230 Vca. Consequentially single phase networks could be maximum 230 V, three phase networks of three wires is 230 V phase-phase but three phase networks four wires is max 230 V phase-neutral

CONNECTIONS FOR REMOTE PANELS PR2 (LOW INSULATION'S SIGNALLING) - TERMINALS 12-13-14

CONNECTIONS FOR REMOTE PANELS PR2 (OVER TEMPERATURE SIGNALLING POWER TRANSFORMER) - TERMINALS 25-26-27

INPUT THERMAL PROBE - TERMINALS 33-34 or 35-36.

PTC (DIN 44081) probe could be used

AUXILIARY RELAY OUTPUT - TERMINALS 29-30-31

contact in switch voltage-free with programmable functions. Contact's capacity 250 V 5 A resistive load

DIMENSIONS

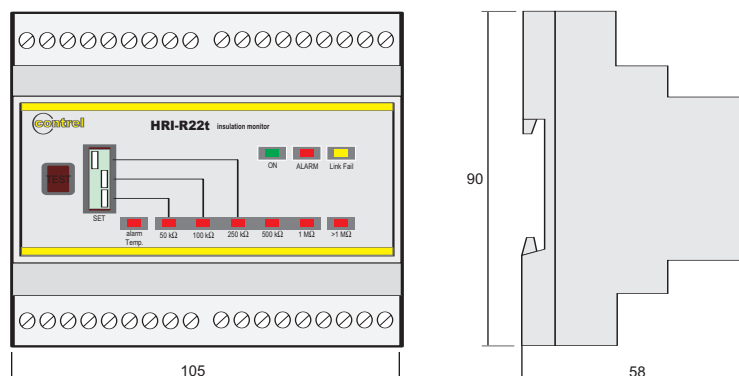

HRI-R24 series

INSULATION MONITORING
VERSIONS FOR USE IN MEDICAL ROOMS

GENERAL



HRI-R24 series

For monitoring 24 V networks (scialytic lamps), monitor HRI-R24 is used. This is able to supply insulation's control adjustable by frontal potentiometer. Frontally there is also testing button for allowing the test of device's correct functionality and eventual remote repeaters panels. Outputs are available for remote repeaters panels PR2 (max 4 panels).

FUNCTIONS AND OPERATORS - LEGENDA

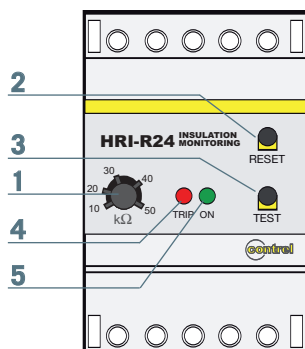

- 1 Potentiometer for regulating trip threshold
- 2 Button of manual resetting
- 3 Test pushbutton
- 4 LED signalling supplied relay
- 5 LED signalling pre-fixed threshold reached

DIMENSIONS

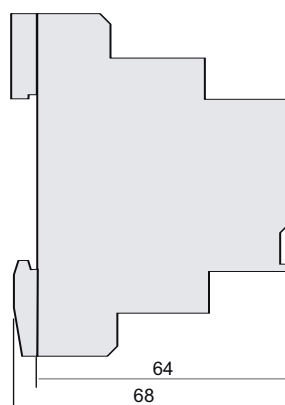
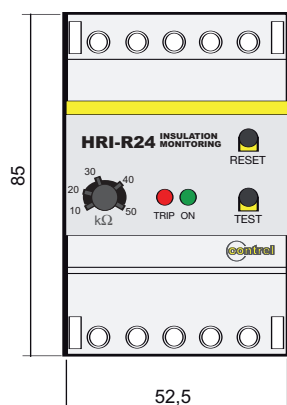

ELECTRIC CHARACTERISTICS

TIPO	HRI-R24
Auxiliary supply	24 Vdc/ac -20 % +10 %
Frequency	50 ÷ 60 Hz
Self-consumption	3 W
Unde-control network voltage	24 Vdc/ac 50 ÷ 60 Hz
Current's measure	< 0.5 mA
Internal impedance for resistive measure	50 kohm
Internal impedance for resistive measure	10 ÷ 50 kohm (by potentiometer)
Visualisation	led of signalling network's presence led of signalling low insulation
Output	for PR2 panel (max 4)
Input	from isolated network 240 Vac/dc (insulation measure)
Voltage of signal circuit	< 24 Vdc
Measure's method	variation of polarity's potential
Insulation's test	2.5 kV 60 sec
Working temperature	-10 ÷ 60 °C
Storing temperature	-20 ÷ 80 °C
Relative humidity	MAX 90 %
Standard regulation	CEI-EN 61010-1 / CEI-EN 61557-8 / VDE 0413 part.8 CEI 64.8/7-710 V2 / IEC 60364-7-710 / UNE 20615 / CEI-EN 61326-1
Assembling according to DIN 50022	snap on DIN rail 35 mm
Dimensions	3 modules DIN 17.5 mm
Protection's degree	IP50 frontal - IP20 case
Connections	by screw terminals max 2.5 mm ²

WIRING DIAGRAMS - LEGENDA

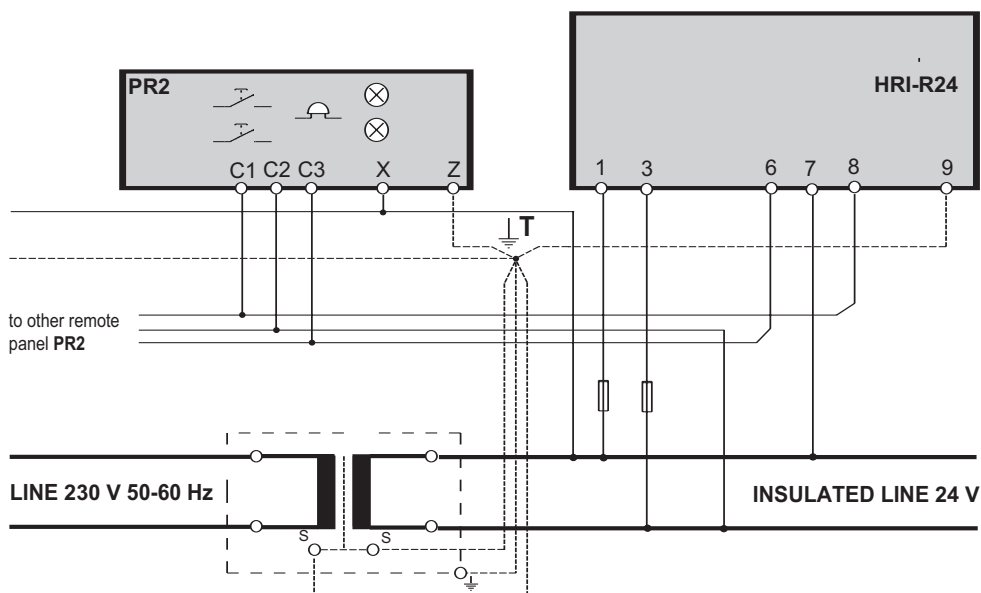

AUXILIARY SUPPLY
terminals 1-3

INSULATION'S MONITORING
terminal 7-9

CONNECTIONS FOR
REMOTE PANELS PR2
(low insulation's signalling)
terminals 6-8

HRI-R40 series HRI-R40W series

INSULATION MONITORING
VERSIONS FOR USE IN MEDICAL ROOMS

GENERAL



HRI-R40 series

This device allows insulation monitoring to earth of supply network and thermal and electric overcharge monitoring of transformer.

This works in order to serve everything requested in specific standard regulation for these applications.

Insulation's resistance monitoring is carried out applying a measure's signalling between isolated network and earth.

Surveying leakage generated to earth it's possible to measure insulation's level.

Modern and sophisticated measure's techniques integrated allow correct measure of insulation's resistance level also in case of strong obstructions, with high harmonic and direct-current components.

HRI-R40 model uses a monitoring signalling with direct-current component. For reducing problems caused by the presence of direct-current components on network (rectifiers), device has a digital filter which is able to divide the majority of direct-current from eventual direct-current components in network.

HRI-R40 could set a large number of programming possibilities with frontal button and 3 digit digital display for visualising measuring and programming parameters.

HRI-R40W series

HRI-R40W version has same fundamental characteristics of previous model but it uses particular measuring technique applying a measure's signal codified and varying, in order to guarantee a correct measure of insulation independently from under-control network type.

Device has two input of temperature's measure (one is optional) for temperature's probe PT100 or PTC (DIN 44081) for monitoring thermal overcharge of insulation's transformer.

There is also a input of current's measure of current transformer for monitoring overcharge on network.

Signalling output are apt for coupling with specific panels of signalling and remote monitoring PR4 (max 2 panels, on request 4 panels).

There is also a output for relay voltage-free with functions adjustable by the user.

Optionally it's available a serial output RS485 for bidirectional communication with monitoring system (PLC, PC, and so on).

Communication's protocol used is MODBUS-RTU.

Specific characteristics make these devices conform to standard regulation:

EN 61557-8
IEC 60364-7-710
VDE 0100 part 710
CEI 64.8/7-710 V2
UNE 20615.

Actually presence in network of strong distortions with high harmonic components (sub harmonic) and direct-current components could cause measure's problems to others techniques.

This solution allow the using of HRI-R40W in network with rectifiers, power's electronics, variable-speed drive and so on.

FUNCTIONS AND OPERATORS - LEGENDA

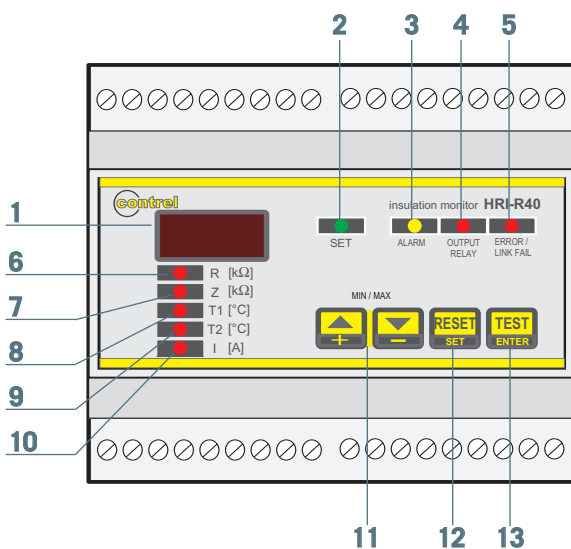

- 1 display for visualising under-control parameters' degree and for visualising settings
- 2 green LED SET for indication of programming status
- 3 yellow LED ALARM for indication alarm for parameter's degree out-threshold
- 4 red LED OUTPUT RELAY for indication status of auxiliary relay output
- 5 red LED ERROR / LINK FAIL for indication alarm of internal failure, lack connection to under-control network, temperature's probe PT100 open or short circuit
- 6 red LED R for indication visualisation of insulation's resistance parameter; flashing light for out-threshold parameter
- 7 red LED Z for indication visualisation of insulation's impedance parameter; flashing light for out-threshold parameter.
- 8 red LED T1 for indication visualisation parameter of transformer's temperature; flashing light for out-threshold parameter.
- 9 red LED T2 for indication visualisation parameter of second sensor temperature; flashing light for out-threshold parameter.
- 10 red LED I for indication visualisation current of network parameter; flashing light for out-threshold parameter.
- 11 button +/- UP/DOWN for selecting parameter that has to be visualised, for regulating device's setting and for visualising maximum and minimum memorized degrees
- 12 button RESET / SET for entering device's programming, for stopping alarms and memorized degrees resetting
- 13 button TEST / ENTER for testing device and remote signalling panels and for confirming SETUP settings

DIMENSIONS

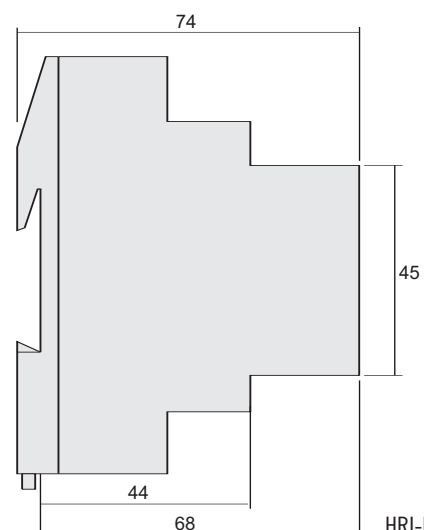
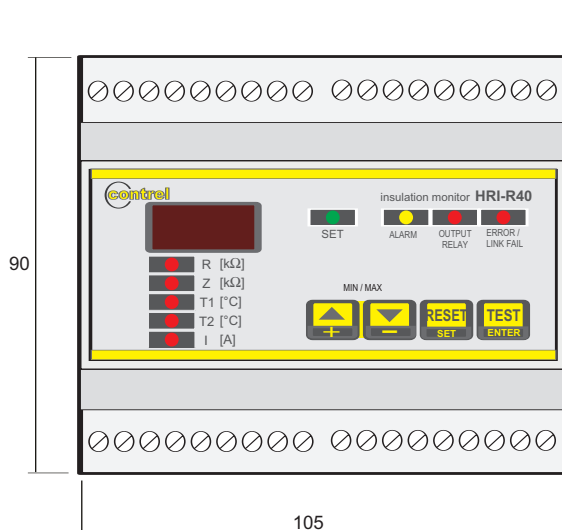

HRI-R40 / HRI-R40W

ELECTRIC CHARACTERISTICS

TIPO	HRI-R40	HRI-R40W
Auxiliary supply	110 - 230 V $\pm 20\%$	110 - 230 V $\pm 20\%$
Frequency	50 \div 60 Hz	50 \div 60 Hz
Self-consumption	5 VA	5 VA
Unde-control network voltage	24 \div 230 V 50 \div 60 Hz	24 \div 230 V 50 \div 60 Hz
Voltage's measure	24 V	24 V
Current's measure	1 mA	1 mA
Internal impedance for resistive measure	200 kohm	200 kohm
Selectable trip threshold	50 \div 500 kohm (low insulation) hysteresis 10 % 20 \div 180 °C (over-temperature) precision 2 % - 1 \div 99.9 A (over-current) precision 2 % - delay 1 \div 60 sec	
Visualisation	insulation and impedance's degree by three digits display 1 \div 999 kohm temperature's degree 0 \div 200 °C (1st and 2nd probe) by display current's value 0 \div 99.9 A by display parameters' configuration output status: - signalling alarms' led - led of signalling output of active relays - led of failed insertion signalling	
Output	for PR4 panel + 1 contact NO-C-NC 5 A - 250 V low insulation, overload + option serial RS485 MODBUS-RTU	
Input	from isolated network 230 Vac (insulation measure) 1st probe PT100 2 or 3 wires (temperature measure) 30 \div 200 °C $\pm 2\%$ 2nd probe PT100 2 or 3 wires (temperature measure) (OPTIONAL) 30 \div 200 °C $\pm 2\%$ CT (overload current' measure max 5 A precision 2 % current transformer ratio selectable 1 \div 40	
Voltage of signal circuit	< 24 Vdc	< 24 Vdc
Measure's method	signalling dc	codified and varying signal
Insulation's test	2.5 KV 60 sec	
Working temperature	-10 \div 60 °C	
Storing temperature	-20 \div 80 °C	
Relative humidity	MAX 90 %	
Standard regulation	CEI-EN 61010-1 / CEI-EN 61557-8 / VDE 0413 part.8 / CEI 64.8/7-710 V2 IEC 60364-7-710 / VDE 0100 part.710 / UNE 20615 / CEI-EN 61326-1	
Assembling according to DIN 50022	snap on DIN rail 35 mm	
Dimensions	6 modules DIN 17.5 mm	
Protection's degree	IP50 frontal - IP20 case	
Connections	by screw terminals max 2.5 mm ²	

WIRING DIAGRAMS - LEGENDA HRI-R40 AND HRI-R40W

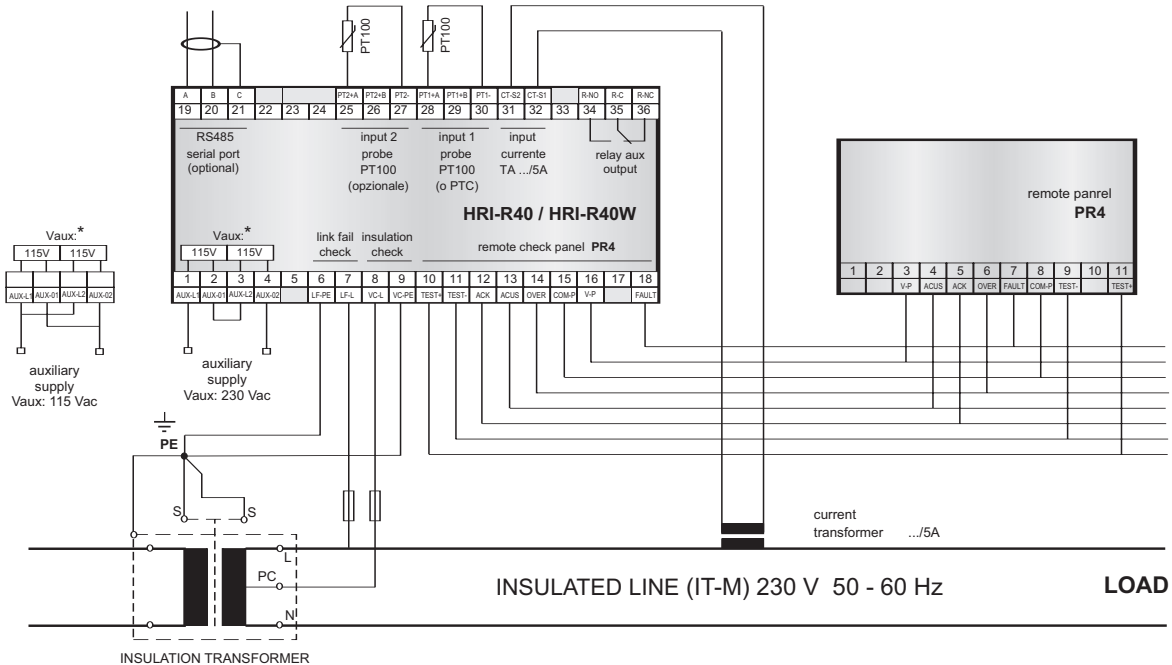

AUXILIARY SUPPLY - TERMINALS 1-2-3-4

supply's section is carried out with double input 115 V nominal for device supplying with 230 V, it is required to connect both sections in series for device supplying with 115 V, it is required to connect both sections in parallel

LINK-FAIL MONITORING - TERMINALS 6-7

both terminals have to be connected between a isolated network's phase and unipotential node (PE) Maximum applicable voltage is 250 V (see insulation's monitoring)

INSULATION'S MONITORING - TERMINALS 8-9

both terminals have to be connected between centre tap of secondary transformer or a isolated network's phase and unipotential node (PE) Maximum applicable voltage is 230 Vca so single phase networks could have max voltage of 230 V, three phase networks three wires could have max voltage of 230 V phase-phase; but three phase networks four wires could have max voltage of 230 V phase-neutral

REMOTE PANEL'S CONNECTIONS PR4 - TERMINALS 10-11-12-13-14-15-16-18

connections for linking to remote panels PR4, Max voltage on these conductors is 24 V

SERIAL PORT RS485 (OPTIONAL) - TERMINALS 19-20-21

terminals A-B (19-20) head to serial bus, terminal C (21) is a mass' reference that could be connected to eventual screen of cable RS485 Standard protocol used is modbus-rtu, documented in a specific handbook [IM833-U]

INPUT TEMPERATURE PROBE 2 (OPTIONAL) - TERMINALS 25-26-27

connections for linking to a temperature's sensor - PT100 (EN 60751) or PTC (DIN 44081) sensor could be used. In case of PT100 probes three wires, it is required to connect compensation's conductor to the same terminal of correspondent conductor. In case of PTC, it is necessary external resistor of 120 ohm min 1/4 W

INPUT TEMPERATURE PROBE 1 - TERMINALS 28-29-30

connections for linking to a temperature's sensor - PT100 (EN 60751) or PTC (DIN 44081) sensor could be used. In case of PT100 probes three wires, it is required to connect compensation conductor to the same terminal of correspondent conductor. In case of PTC, it is necessary external resistor of 120 kohm min 1/4 W

INPUT FOR CURRENT MEASURE - TERMINALS 31-32

connection for external current transformer with secondary 5 A (current transformer ratio is programmable); if there is 3-phase network must be used the special adapter type TSA-03 for 3 current transformer to permit to monitor in the insulation relay the highest value of the 3-phase currents. Only the module of the current value is measured (i.e. it is not important S1-S2 connection sequence).

OUTPUT AUXILIARY RELAY - TERMINALS 34-35-36

switch contact free from voltage and with programmable functions. Contact's performance MAX 250 V 5 A resistive load